

TECHNICAL DATA SHEET

UPM Euca

ECF Bleached Eucalyptus Kraft Pulp
Pulp mill: UPM Fray Bentos

Date of issue: 23.11.2020

PULP CHARACTERISTICS

	Typical value	Spec
Brightness, ISO % ISO 2470-1; ISO 3688 handsheet	90	≥ 89
Impurities, mm ² /kg ISO 5350-2	1	
Extractives, % SCAN-CM 49:93	0,1	≤ 0,2
Ash content, % ISO 1762	0,4	≤ 0,7
pH 6388-2	5,7	5,0-7,0

REFINABILITY

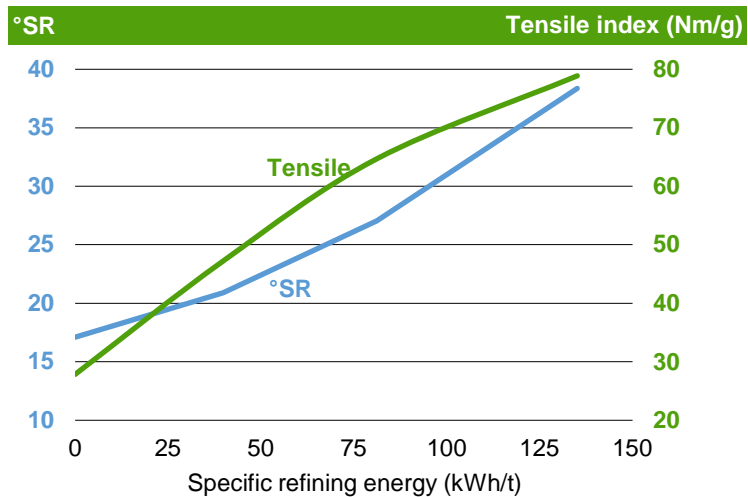

FIBRE CHARACTERISTICS

	Typical value
Fibre length, mm Metso FS5	0,9
Coarseness, mg/m Metso FS5	0,06

TEAR AND BULK AT TENSILE

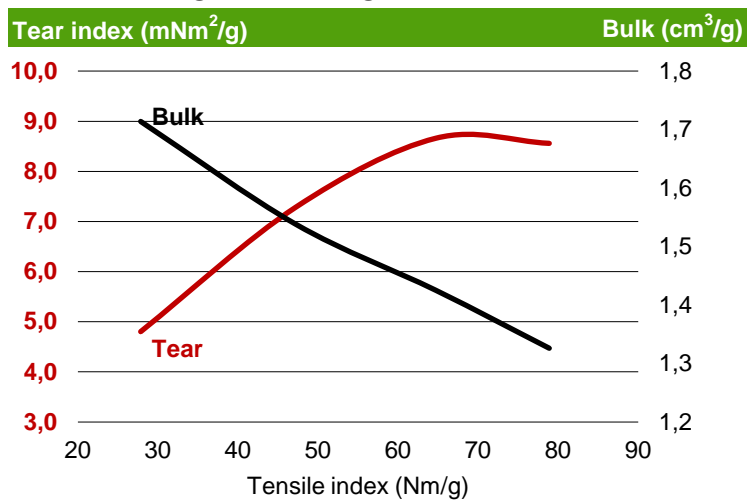

RAW MATERIAL

Hardwood

Eucalyptus 100%
E. grandis, dunnii, globulus, maidenii

Specific Refining Energy	CSF	SR number	Tensile index	Stiffness index	Tear index	Scott Bond	Bulk	Opacity	Air res. Gurley
kWh/t	ml		Nm/g	kNm/g	mNm ² /g	J/m ²	cm ³ /g	%	s
0	568	17	28	4,5	4,8	118	1,71	78,3	2,0
40	500	21	47	5,9	7,3	231	1,54	75,8	3,5
81	406	27	65	6,9	8,7	408	1,43	74,0	9,1
135	288	38	79	7,6	8,6	754	1,33	71,9	42,0
30	516	20	43	5,6	6,7	204	1,58	76,4	3,1
67	438	25	59	6,6	8,2	349	1,46	74,6	7,2
95	375	30	68	7,1	8,6	498	1,40	73,5	17,7
46	485	22	50	6,1	7,5	259	1,52	75,5	4,4
70	431	25	60	6,7	8,3	360	1,46	74,5	7,6
101	362	31	70	7,2	8,6	537	1,39	73,2	21,4

Typical values are averages from all mill quality control samples during 2019-2020. They are given in good faith to represent mill performance and do not constitute contractual undertaking. Values in the table are mean (indicative) values from pulp testing with Voith-Sulzer refining, using standard water. Specific Edge Load 0,5 J/m, ISO testing methods (H 50%, 23 °C, 60 g/m² sheets).

UPM Euca

Bale marking

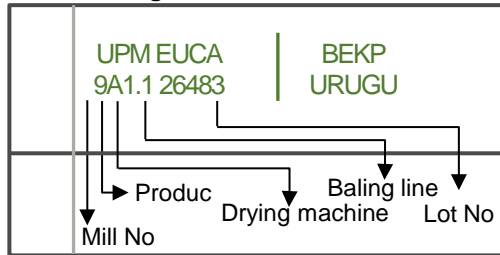

Standard Bale

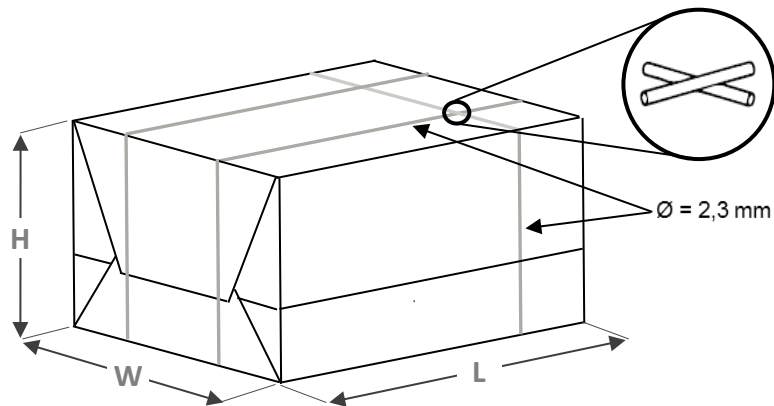

Standard bale unit configuration

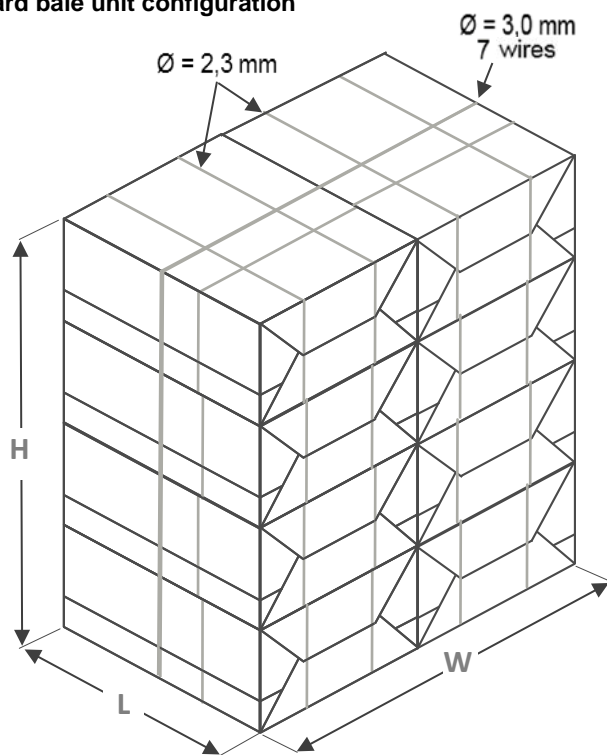

Sheets

Size:	92 x 67 cm
Grammage:	1000 - 1200 g/m ²

Standard bale

Size:	L = 96 cm
	W = 69 cm
	H = 45 cm
Weight:	250 kg
Wrapping:	Pulp sheets (unwrapped on demand)
Markings:	Green watersoluble inkjet printing. Country, company name, product code and bale number on both sides, on every second bale.
Wires:	3 galvanized wires, diameter 2,3 mm.

Standard unit

Size:	L = 96 cm
	W = 139 cm
	H = 180 cm
Weight:	2000 kg (8x250 kg)
Wires:	7 galvanized wires, diameter 3,0 mm

UPM-Kymmene Corporation

Alvar Aallon katu 1
PO Box 380
FI-00101 Helsinki, Finland

Contact information:

Tom Hultholm Senior Product Manager, tel. +358 400 589 529
tom.hultholm@upm.com
www.upmpulp.com

UPM Euca

Big bale

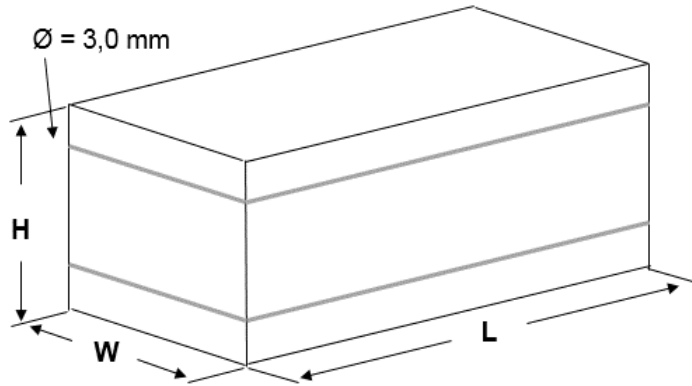

Sheets

Size: 92 x 67 cm

Grammage: 1000 - 1200 g/m²

Big bale

Size: L = 180 cm

W = 94 cm

H = 68 cm

Weight: 1000 kg

Wrapping: No wrapping

Markings: Green watersoluble inkjet printing.
Country, company name, product code
and bale number on both sides.

Wires: 2 galvanized wires,
diameter 3,0 mm

Big bale unit configuration

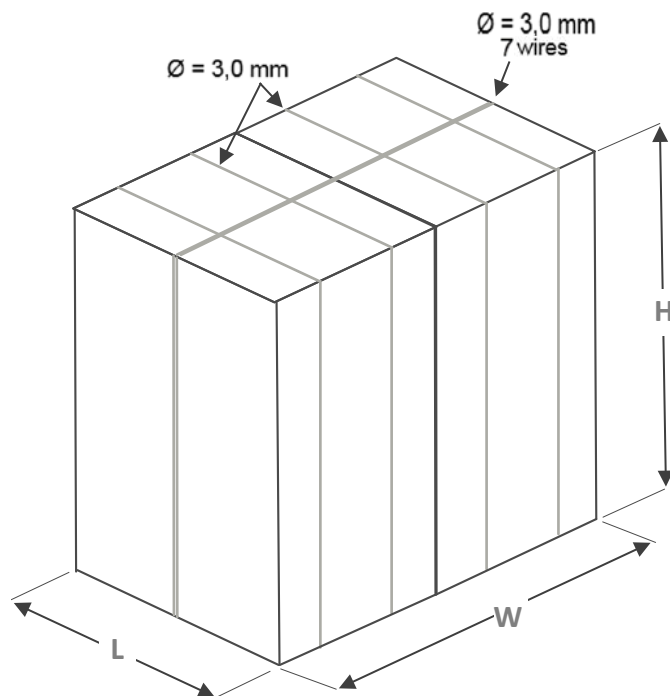

Big bale unit

Size: L = 94 cm

W = 137 cm

H = 180 cm

Weight: 2000 kg (2x1000 kg)

Wires: 7 galvanized wires,
diameter 3,0 mm

UPM-Kymmene Corporation

Alvar Aallon katu 1
PO Box 380
FI-00101 Helsinki, Finland

Contact information:

Tom Hultholm Senior Product Manager, tel. +358 400 589 529
tom.hultholm@upm.com
www.upmpulp.com